

THE NATIONAL ASSOCIATION OF MEMORIAL MASONS

# MEMORIAL SPECIFICATION GUIDE



Materials  
Finishes  
Shapes  
Lettering  
Ornament

This guide, which should be read in conjunction with the NAMM booklet *The Recommended Code of Working Practice*, is intended to help avoid ambiguity and misunderstanding in the British memorial industry. Its aim is to improve communication between manufacturers, wholesalers and retailers, cemetery and church authorities, and their customers.

When producing a new memorial, consideration must be given to the customer's requirements, location and cemetery and churchyard regulations. A durable, naturally quarried material should be selected which will accommodate the required design and lettering.

## Materials

All materials used in the production of memorials have variations within the slab. Colour names can be misleading and are only given as a general guide.

### "GRANITES"

These are the hardest materials and cover all igneous stones. Colours range from black to light grey, pink to red, blue and green. Some have a pearl effect when polished showing the mica within the rock.

**Finishes:** All types

### "MARBLE"

Carrara, sometimes called Sicilian is the usual marble used for memorials. Marble is generally white and has a blue grey vein. As it weathers it turns grey and becomes sugary, due to surface erosion.

**Finishes:** All types except polishing

### "LIMESTONE"

The material is formed under water and contains shells, as in Portland stone. The colour ranges from cream to beige. Nabresina from Trieste in Italy is denser and finer grained than many British Stones.

**Finishes:** All types except polishing

### "SANDSTONE"

Silica stones, such as York, can be harder and more durable than Limestone. The colours vary from sandy to grey.

**Finishes:** Fine rubbed, tooled or pitched.

### "SLATE"

Chemically similar to clay, this material is compressed into laminated form and is very strong. It can be split or sawn into thin slabs. It is usually blue/black or green.

**Finishes:** Fine honed or Riven - split through the lamination

## Finishes

### RUSTIC

Natural rock-like appearance achieved with a minimum of work to split away unwanted stone.

### PITCHED

Natural rock finish left by splitting the material by hand or machine.

### PUNCHED

As rustic but highest spots reduced by tooling.

### FINE PUNCHED

As punched but material is worked to give a reasonably uniform surface.

### FINE AXED

A rustic finish finely tooled to give an even surface, used on rough granite for inscription panels.

### FLAME TEXTURED

Surface is spalled or exfoliated by the application of heat, giving a uniform appearance similar to riven.

### RIVEN

Naturally split giving a smooth undulating surface, only applies to slate.

### TOOLED

Various textures achieved by masoning, normally a dressed finish showing tool marks.

### SPARROW PECK

A tooled even texture achieved with a finely pointed chisel.

### SANDED

Fine rubbed or sandblasted to remove the irregular markings, giving a uniform surface.

### EGGSHELL

Non-reflective smooth matt finish.

### HONED

Finish between eggshell and polished.

### POLISHED

A gloss polished finish giving a glass-like smooth reflective surface.

# Standard Headstone Shapes

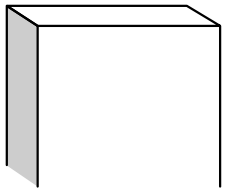

**H1**  
Square Top

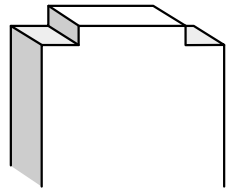

**H2**  
Checked Top

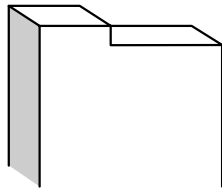

**H3**  
Raised Shoulder

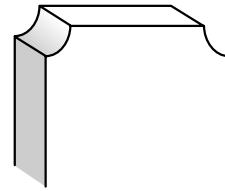

**H4**  
Square Top and  
Scotia Corners

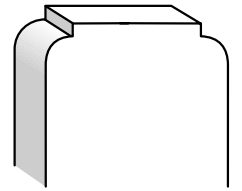

**H5**  
Square Top Checked and  
Rounded Shoulders

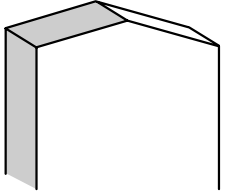

**H6**  
Peon Top

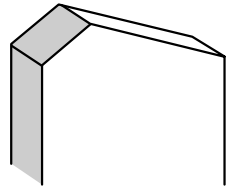

**H7**  
Offset Peon Top

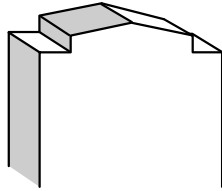

**H8**  
Peon with Checks

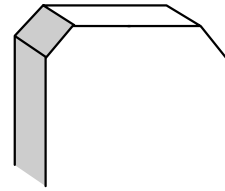

**H9**  
Square Top and  
Splayed Corners

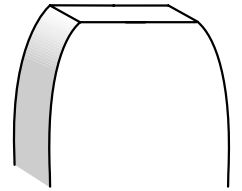

**H10**  
Square Top  
Gothic Shoulders

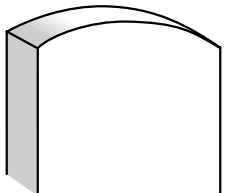

**H11**  
Oval, Arc or Cambered

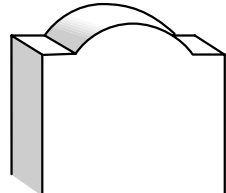

**H12**  
Oval with Shoulders

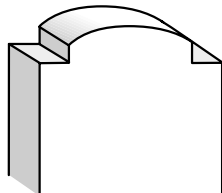

**H13**  
Oval with Checks

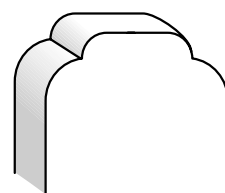

**H14**  
Square Top  
Double Rounded Shoulders

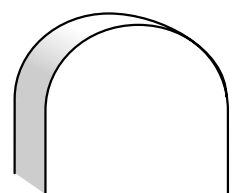

**H15**  
Half Round

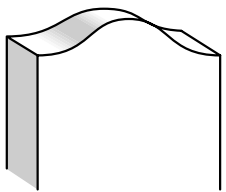

**H16**  
Ogee Top

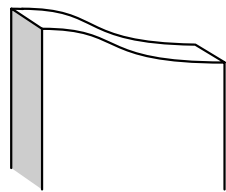

**H17**  
Half Ogee Top

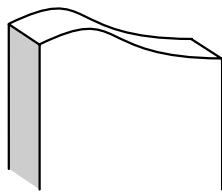

**H18**  
Serpentine Top

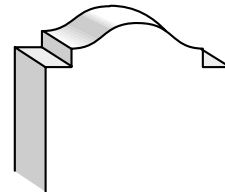

**H19**  
Ogee with Checks

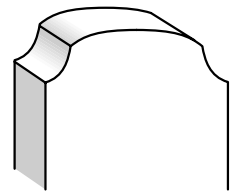

**H20**  
Oval Top  
Scotia Shoulders

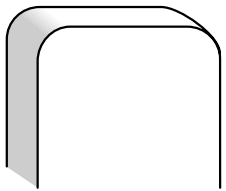

**H21**  
Square Top  
Rounded Shoulders

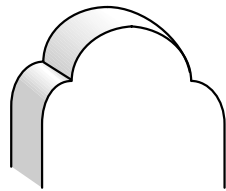

**H22**  
Round Top  
Rounded Shoulders



**H23**  
Checked Oval Top  
Checked Rounded Shoulders

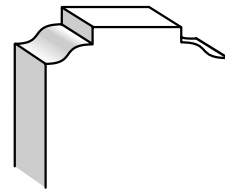

**H24**  
Square Top  
Ogee Shoulders

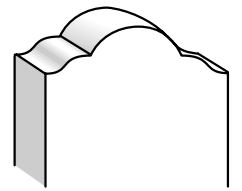

**H25**  
Oval Top  
Ogee Shoulders

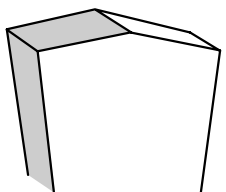

**H26**  
Peon Top with Tapered  
Sides

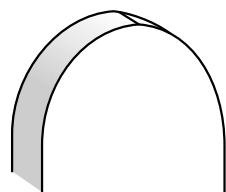

**H27**  
Norman

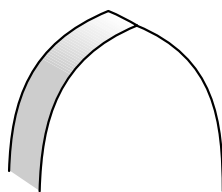

**H28**  
Gothic

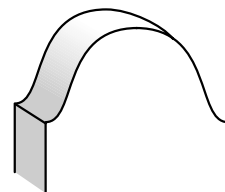

**H29**  
Deep Ogee

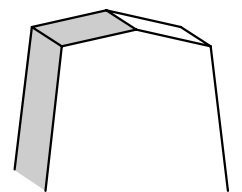

**H30**  
Peon Top with  
Splay Sides

# Standard Headstone Shapes (continued)

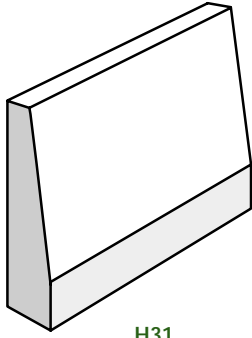

**H31**  
Desk

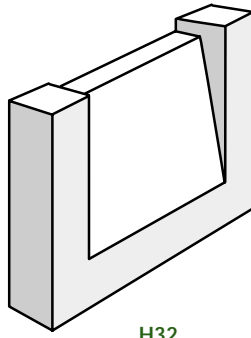

**H32**  
Desk with Pilasters

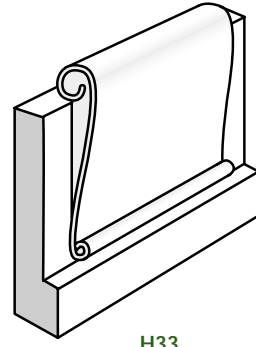

**H33**  
Scroll with Side Panels

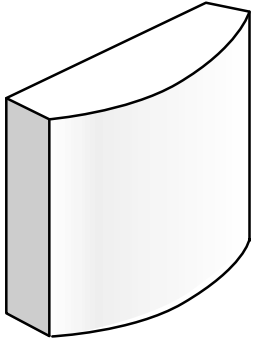

**H35**  
Convex Face

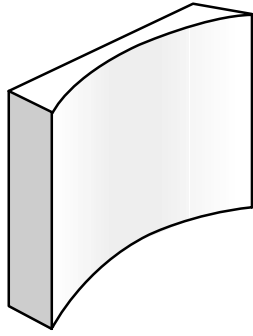

**H36**  
Concave Face

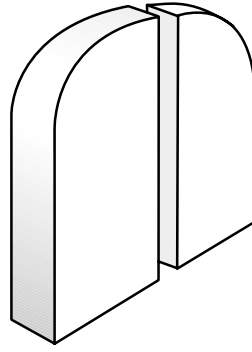

**H37**  
Split Headstone

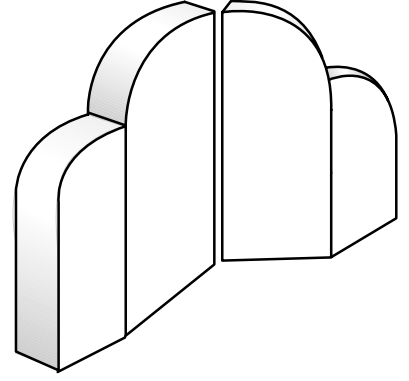

**H38**  
Split with Wings

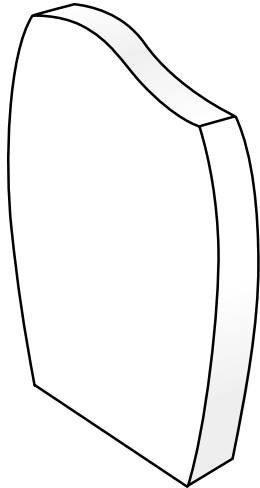

**H39**  
Serpentine Top  
Curved or Barrel Sides

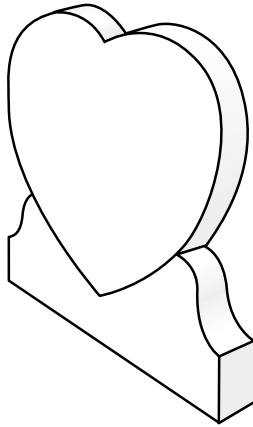

**H40**  
Heart  
With ogee shoulders

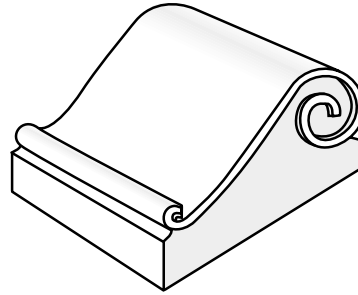

**H41**  
Recumbent Scroll

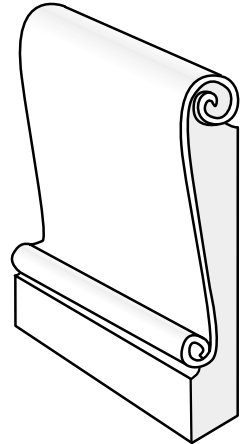

**H42**  
Upright Scroll

# Plaques and Tablets

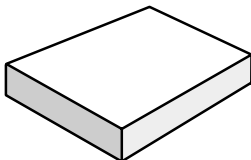

**P1**  
Plain

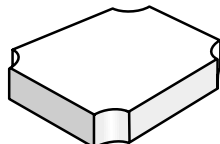

**P2**  
Scotia

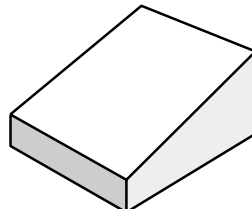

**P3**  
Desk

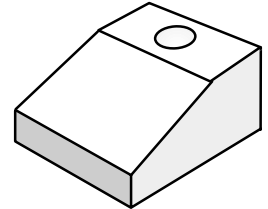

**P4**  
Desk with Container Hole

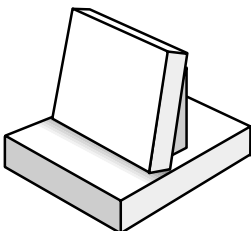

**P5**  
Plain Plaque, Rest & Base

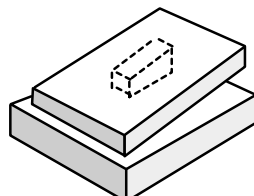

**P6**  
Plain Plaque, Riser & Base

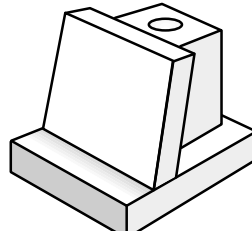

**P7**  
Plain Plaque, Vase & Base

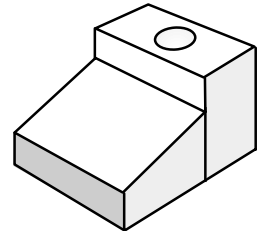

**P8**  
Desk & Vase

# Lawn Type Bases

*shown with typical dowel and container holes*

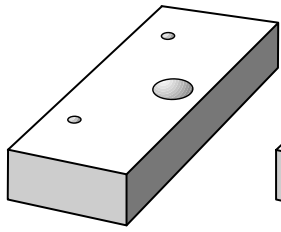

**B1**  
Square

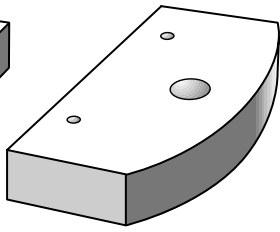

**B2**  
Oval

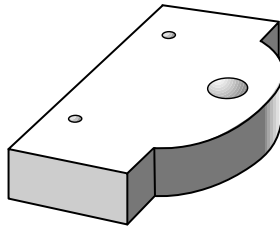

**B3**  
Bow Front

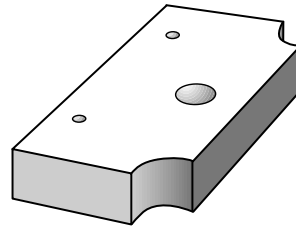

**B4**  
Scotia Corners

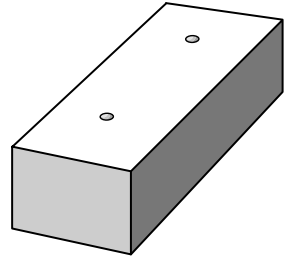

**B5**  
Block

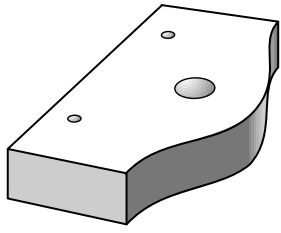

**B6**  
Ogee

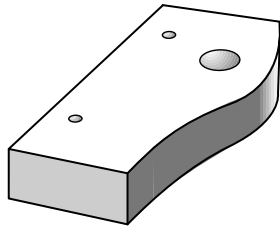

**B7**  
Serpentine

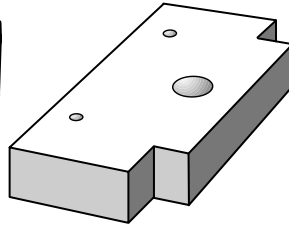

**B8**  
Checked Corners

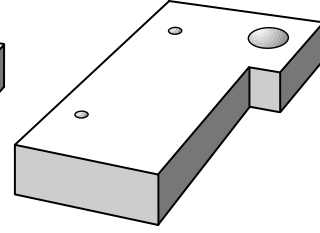

**B9**  
Offset

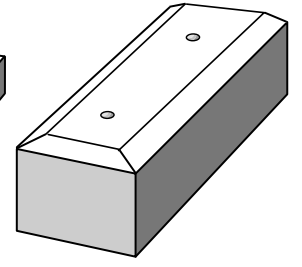

**B10**  
Weathered Block

# Crosses

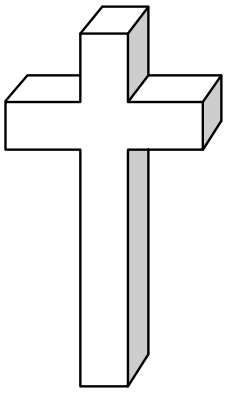

**C1**  
Latin

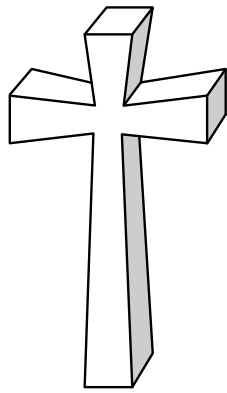

**C2**  
Maltese

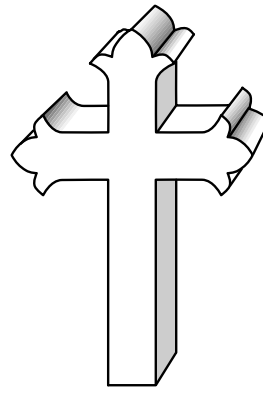

**C3**  
Trefoil

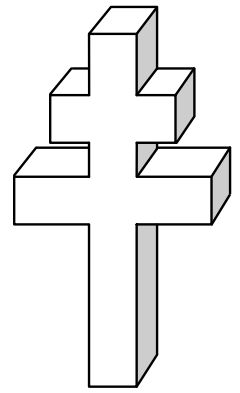

**C4**  
Cross of Lorraine

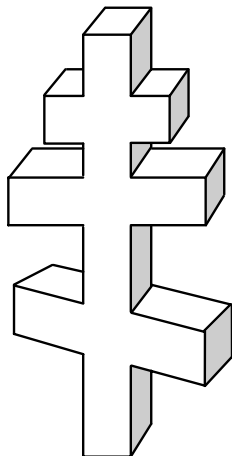

**C5**  
Russian Orthodox

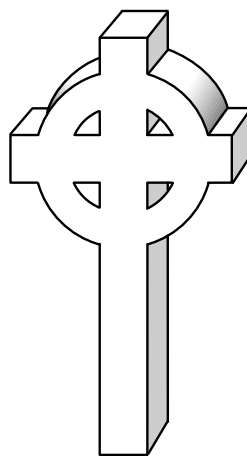

**C6**  
Wheel

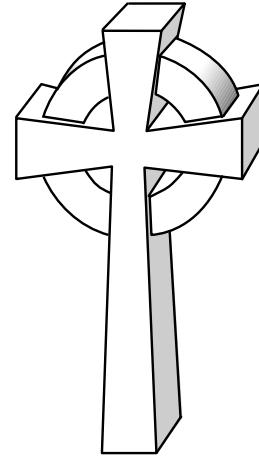

**C7**  
Celtic

# Die and Step Bases for Crosses

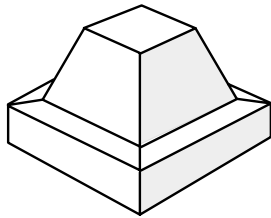

**DS1**  
Die and Weathered Plinth

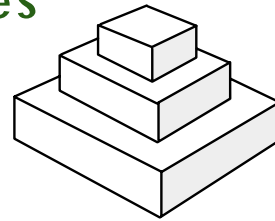

**DS2**  
Three Tier Stepped Base

# Books and Supports

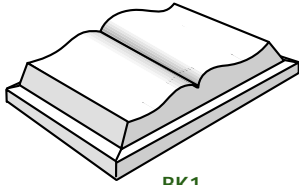

**BK1**  
Open Book with Curved Pages

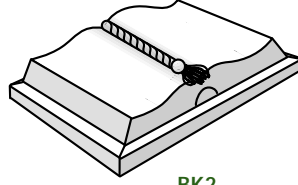

**BK2**  
Open book with Curved Pages and Tassel

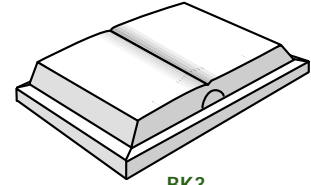

**BK3**  
Open Book with Flat Pages

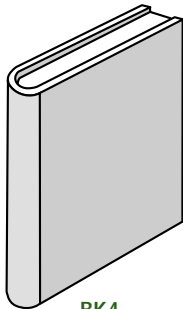

**BK4**  
Closed Book

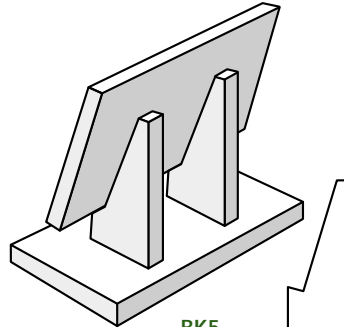

**BK5**  
Tick Rest

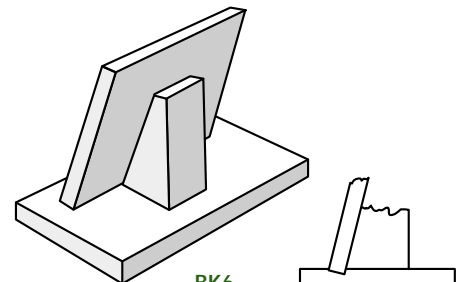

**BK6**  
Plain Rest

# Closures

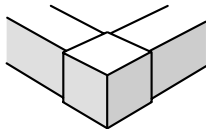

**CL1**  
Post with Kerbs

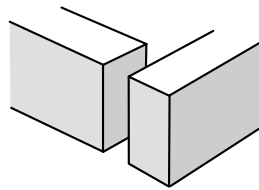

**CL2**  
Square Return

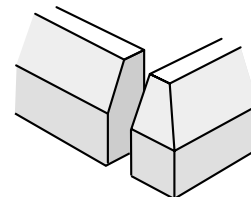

**CL3**  
Mitred Return

# Kerb Ends

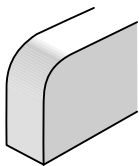

**K1**  
Half Bullnose

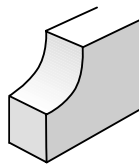

**K2**  
Scotia

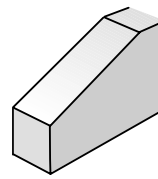

**K3**  
Splay

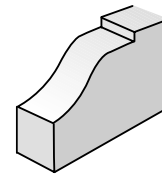

**K4**  
Check & Ogee

# Kerb Sections



**K5**  
Square



**K6**  
Deep Chamfer or Splay



**K7**  
Check or Rebate



**K8**  
Scotia



**K9**  
Chamfer



**K10**  
Half Bullnose



**K11**  
Roll Top



**K12**  
Flat

# Posts

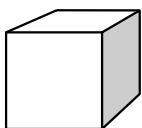

**P1**  
Plain

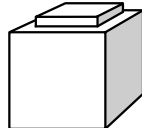

**P2**  
Check

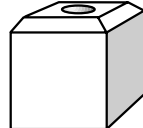

**P3**  
Chamfer with Container Hole

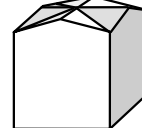

**P4**  
Mitre

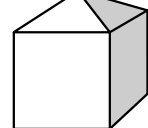

**P5**  
Peon

# Kerb Surrounds Ledgers and Cover Slabs

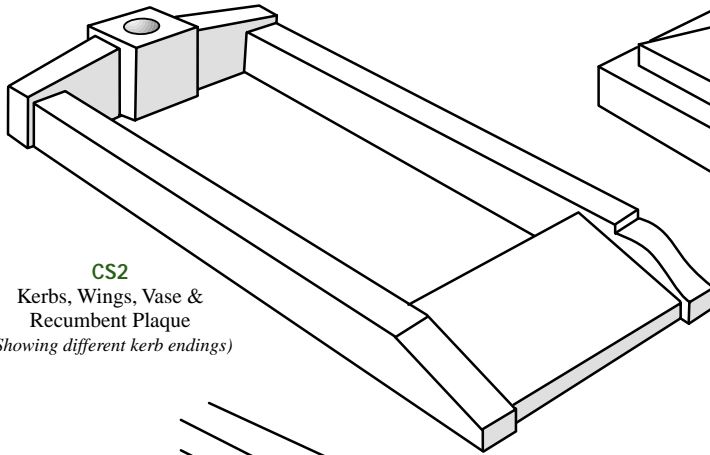

**CS2**  
Kerbs, Wings, Vase &  
Recumbent Plaque  
(Showing different kerb endings)

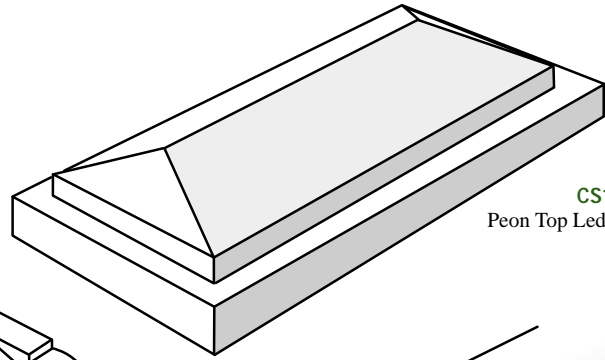

**CS1**  
Peon Top Ledger on Slab

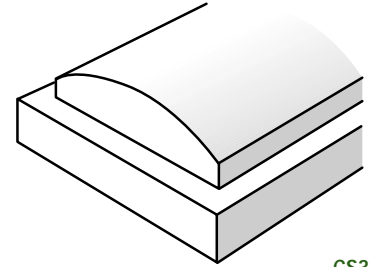

**CS3**  
Oval Ledger on Slab

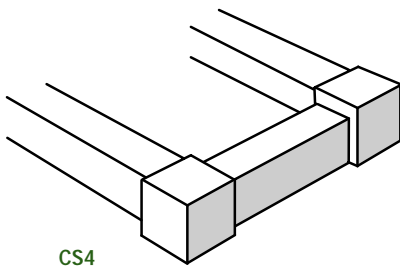

**CS4**  
Posts and Kerbs

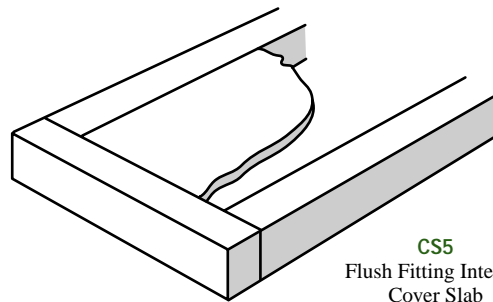

**CS5**  
Flush Fitting Internal  
Cover Slab

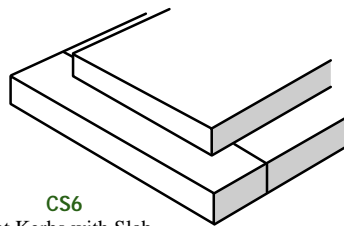

**CS6**  
Flat Kerbs with Slab

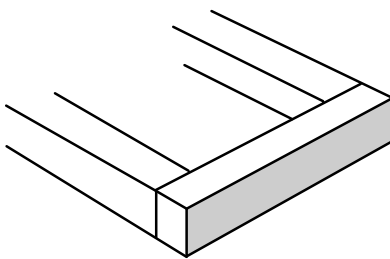

**CS8**  
Quoin Ends

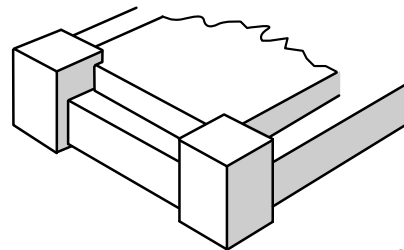

**CS7**  
Top Fitting Cover Slab

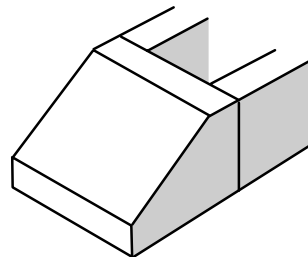

**CS9**  
Full Width Foot Plaque

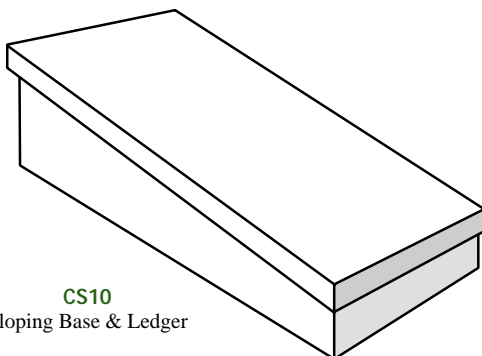

**CS10**  
Sloping Base & Ledger

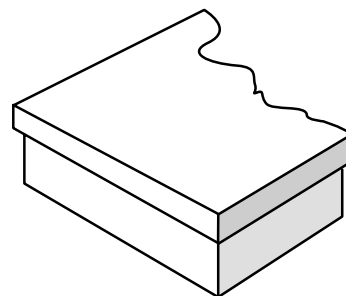

**CS11**  
Over Fitting Cover Slab

## Examples of Canopies

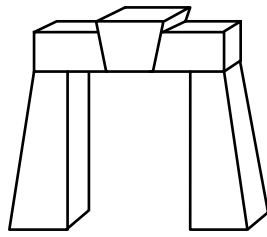

CA1  
Canopy with Keystone

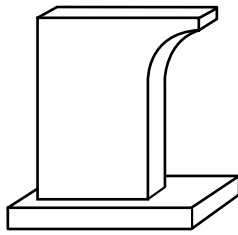

CA2  
Side Canopy

## Obelisk

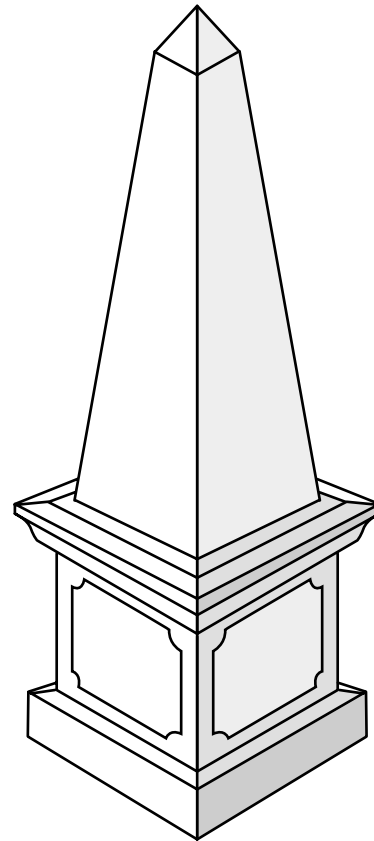

Obelisk

## Vases

Vases should be in keeping with the general design of the rest of the memorial and, if possible, provide room for an inscription.

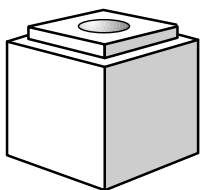

V1  
Check Top

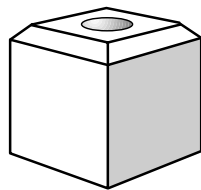

V2  
Chamfer Top

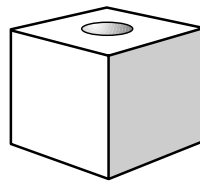

V3  
Plain

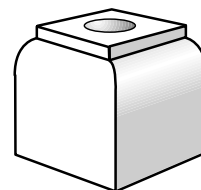

V8  
Ovolo

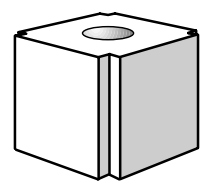

V9  
Check Sides

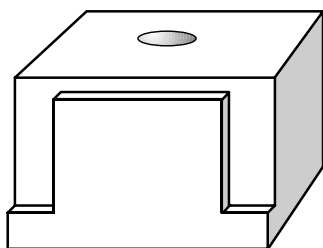

V10  
Panelled

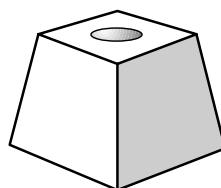

V5  
Splay Sides

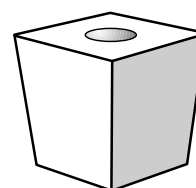

V6  
Tapered Sides

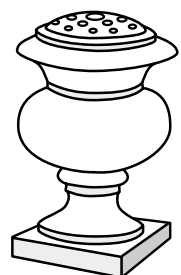

V4  
Round with Container



# Mouldings & Shapes

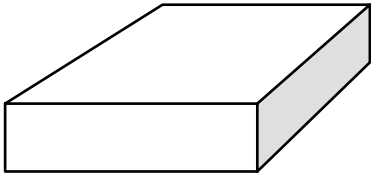

Square

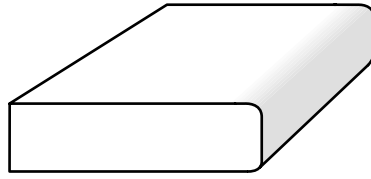

Pencil Round

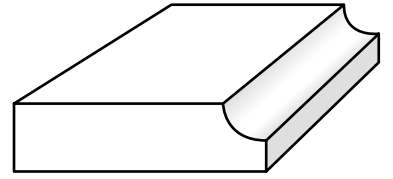

Scotia

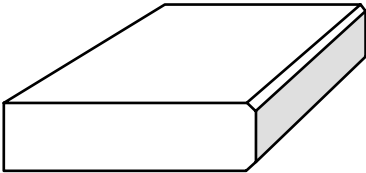

Arris

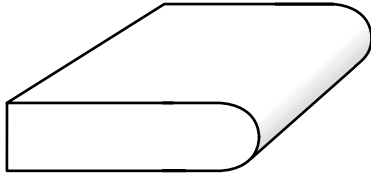

Bullnose

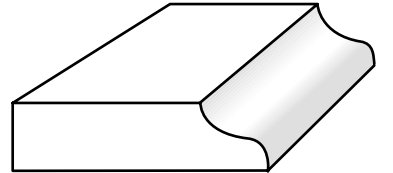

Ogee

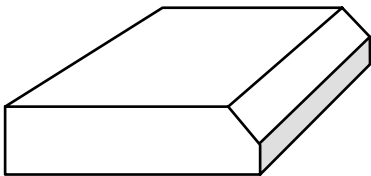

Chamfer

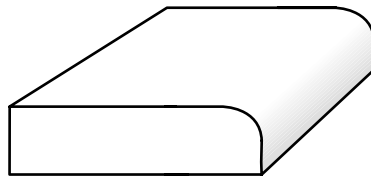

Half Bullnose

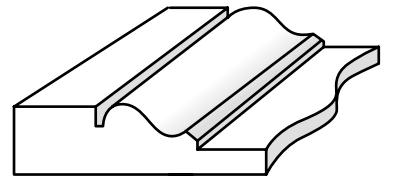

Sunk Panel with Ogee Mould

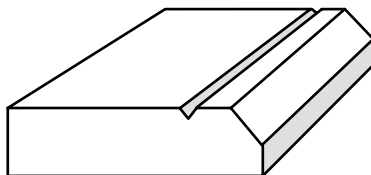

Chamfer/V Line

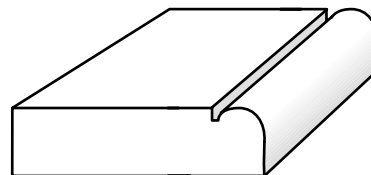

Bead 1

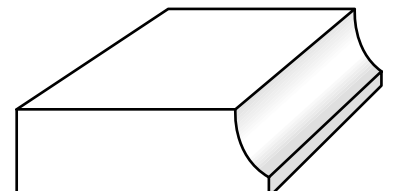

Cavetto

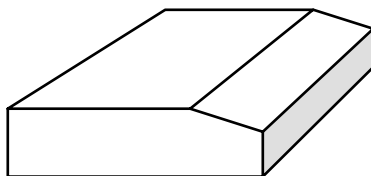

Weathered

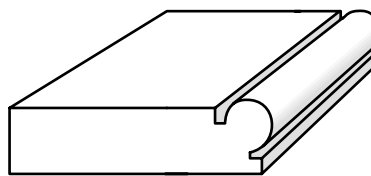

Bead 2

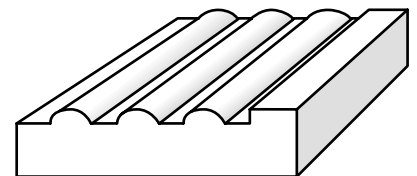

Reed

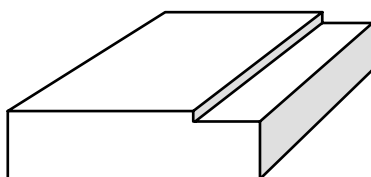

Sunk Margin

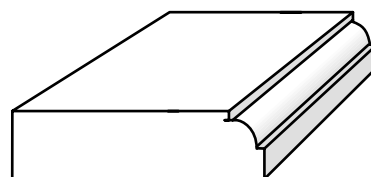

Ovolo

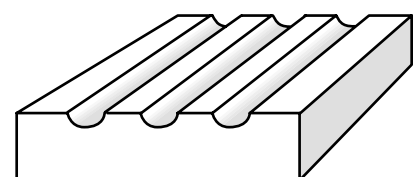

Flute

# Lettering

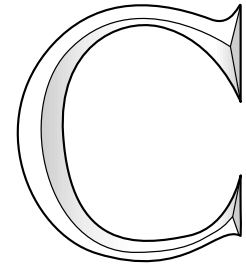
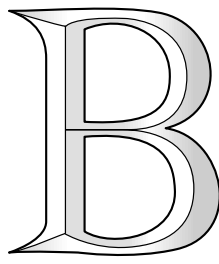
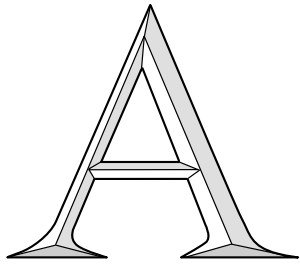

**Incised Roman Capitals**

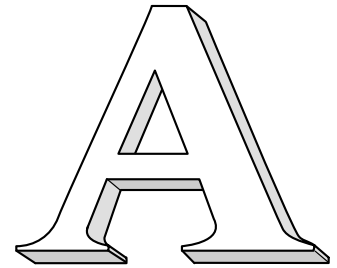
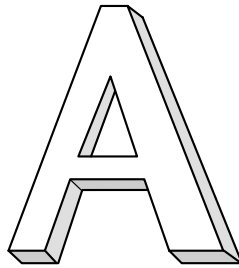
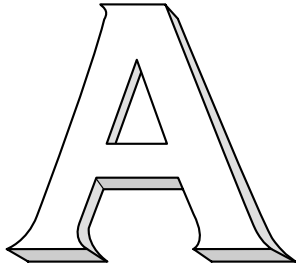

**Raised or Embossed**

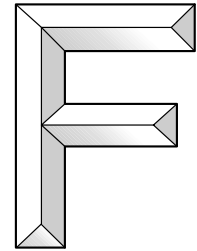
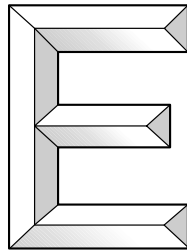
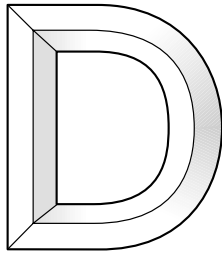

**Incised Sans Serif or Block Characters**

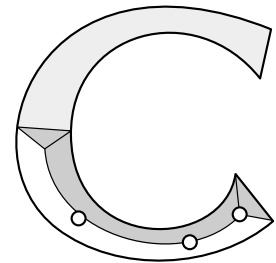
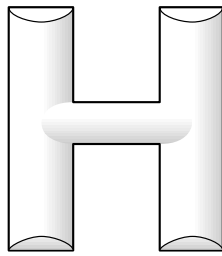
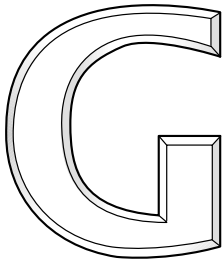

**Square Incised**

**Grit Blasted**

**Flush Lead**

The material is drilled at an angle to the face to give a key. Lead is beaten in and cleaned off smooth

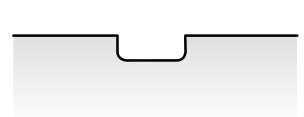
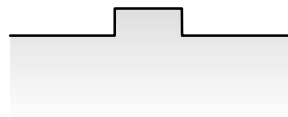
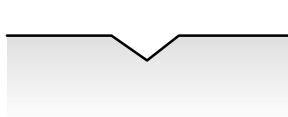
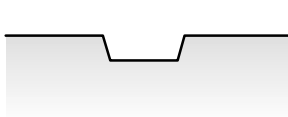

Square Incised

Incised

Embossed

Sand Blasted

## Cross Sections

### Method 1

Rough out the letter shape as shown on plan and drill holes at different angles to form a key, then beat in the lead, filling the holes and rough cut letter, but leaving the lead a uniform, smooth thickness above the surface of the stone, trimming the lead to form the letter shape and enamelling, usually black.

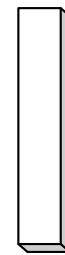
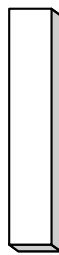
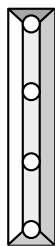

### Method 2

Drill the holes directly into the surface of the stone at different angles, then beat in the lead repeating the same procedure as Method 1.

## Raised Lead Letters

There are two methods of creating raised lead letters as shown above.

# Ornamentation



Skin Carved  
on Black Granite



Sunk Relief



Outline



Skin Carved  
on White Marble



Etched



Etched and Shaded



Photo Blast



**Published by:**

NATIONAL ASSOCIATION OF MEMORIAL MASONS  
27A ALBERT STREET  
RUGBY  
WARWICKSHIRE CV21 2SG  
TEL: 01788 542264 ♦ FAX: 01788 542276  
e.mail: enquiries@namm.org.uk ♦ Web site: www.namm.org.uk

**© COPYRIGHT NAMM**

No reproduction by any method whatsoever of any part of this publication is permitted without the prior written consent of the copyright owners.

The National Association of Memorial Masons is indebted to  
**R. Lidster Ltd**



the major sponsor of this publication.

*Also to supporting sponsor*

**A & J Robertson (Granite) Ltd.**

Your Local Distributor: